

ATOMIC CARBON SUBLIMATION SOURCE SUKO-A

- Thermal sublimation of atomic carbon
- Only pyrolytic graphite and tantalum parts in hot area
- Water-cooled power feedthrough
- Cooling shroud and shutter optionally available
- Compatible with UHV analysis systems and MBE growth chambers

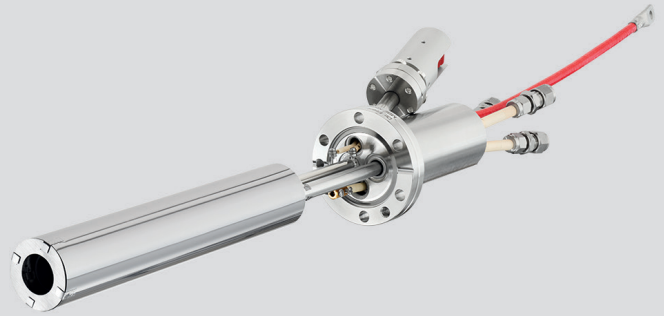

SUKO-A 40 on DN40CF (O.D. 2.75") flange

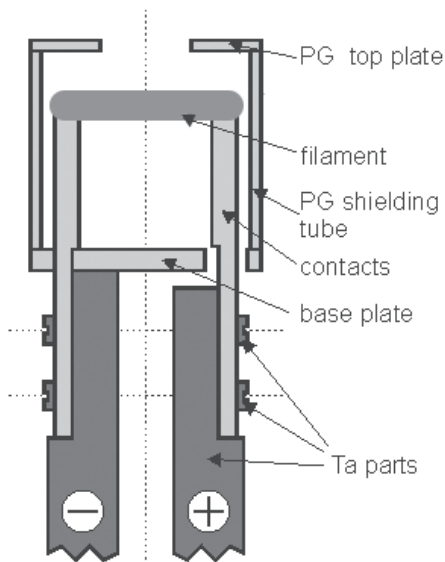

Main parts of the SUKO-A assembly

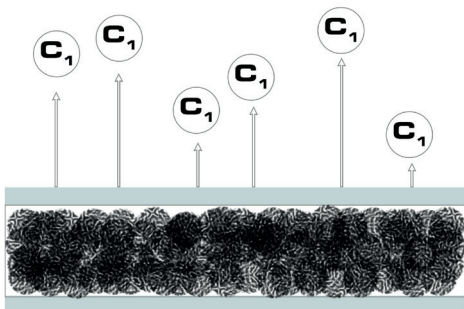

Schematic effusion of highly reactive C_1 carbon

The Carbon Sublimation Source SUKO-A provides pure, highly reactive atomic carbon with a vast majority of C_1 instead of the large percentage of C_2 and C_3 clusters (~75%) that are naturally released during the sublimation of graphite.

The extraordinary filament consists of a refractory metal tube, filled with carbon. At temperatures above 1800°C, carbon diffuses through the tube and sublimates from its outer surface. The tube itself acts like a filter, letting only atomic carbon pass.

Disturbing outgassing of undesirable material is effectively prevented by the proven design of the SUKO-A, using solely pyrolytic graphite around the filament. The power feedthrough is water-cooled and process-safe without any water or vacuum welding seam. Direct heating of the filament by a DC power supply enables reliable and easy handling.

Appearance and dimensions of the SUKO-A are similar to the well-proven standard Carbon Sublimation Source SUKO. In fact, with a few spare parts users can convert every existing SUKO source into a SUKO-A, and vice versa, in their own laboratory.

The SUKO-A is available in two sizes, on either DN40CF (O.D. 2.75") or DN63CF (O.D. 4.5") flange. It can be easily mounted into common UHV analysis systems or MBE growth chambers.

Cooling shroud and shutter, highly recommended for the majority of applications, are optionally available.

Applications

Today the main fields of application for the SUKO-A source are fundamental research, isotopically pure production of graphene by Molecular Beam Epitaxy and

simulation of processes in outer space.

Further fields are likely to emerge once the still new source concept attracts more attention in the market.

The following table shows the required electrical power and typical flux rates at 100 mm working distance of the currently available SUKO-A models.

Source type	Mounting flange	Electrical power	Carbon flux
SUKO-A 40	DN40CF (O.D. 2.75")	500 W	0.1 nm/min
SUKO-A 63	DN63CF (O.D. 4.5")	1000 W	0.5 nm/min

Technical Data

Mounting flange	DN40CF (O.D. 2.75") or DN63CF (O.D. 4.5")
Dimensions in vacuum	L=250-400 mm / D=36 mm or D=55 mm
Filament type	refractory metal tube filled with carbon, shielded with PG parts
Thermocouple	W5%Re/W26%Re (type C)
Bakeout temperature	max. 250°C
Operating temperature	max. filament temperature 2300°C
Cooling	water-cooled electrical contacts, water flow min. 30 l/h; separate water (or LN2) cooling shroud
Option	integrated rotary shutter (S)

