

ORGANIC MATERIAL EFFUSION CELL OME

- Patented Thermal Conduction Cooling (TCC)
- Ideal for evaporation of organic materials in UHV and OLED applications
- Fast and precise temperature control
- Temperature range 15-300°C
- Full UHV and MBE compatibility

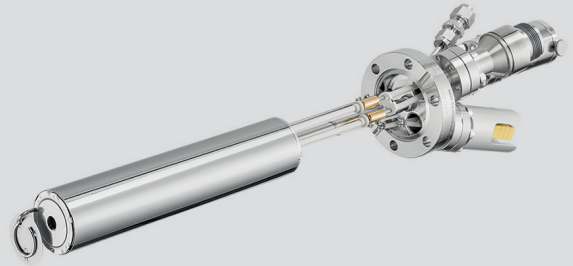

OME 40-2-25-S on DN40CF (O.D. 2.75") flange

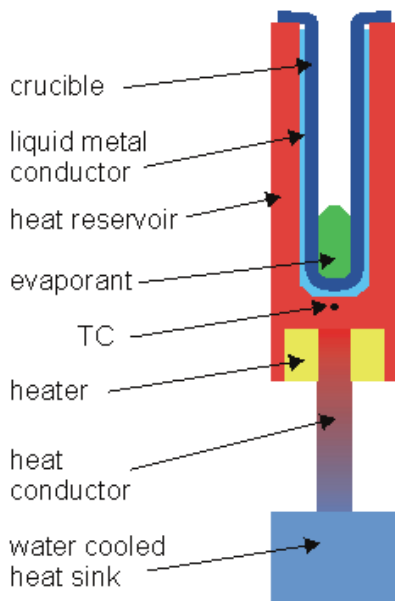

Schematic of the TCC technique as applied in the OME

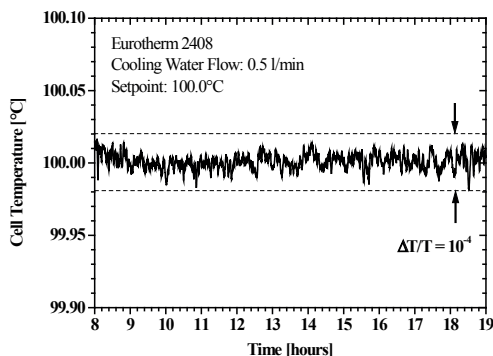

Temperature fluctuation during long term operation of an OME cell

The Organic Material Effusion Cell OME is specially designed for the evaporation or sublimation of high vapor pressure materials, notably sensitive organic substances, at operating temperatures up to 300°C. It can likewise be used for other materials typically evaporated at very low temperatures, e.g. alkali metals.

Due to its patented Thermal Conduction Cooling with encapsulated heater unit, the OME offers drastically improved operation properties below the lowest temperature limit of common Knudsen-type effusion cells.

The novel TCC concept involves a liquid metal used as a thermal conductor that provides a direct thermal connection between crucible and heat reservoir, leaving no isolating voids.

Conventional effusion cells show a poor cooling efficiency, due to the T^4 -dependency of emitted radiation power, rendering precise temperature control below 150°C very difficult.

By contrast, the OME uses the linearity of the heat transfer between a heated reservoir and a cooled heat sink to obtain a high cooling rate even at very low operating temperatures. Rapid cooling down, low thermal time constants and a stable temperature control are thus achieved.

The diagram on the left shows the excellent long term temperature stability of the OME cell. During a periode of 10h of operation the temperature does not fluctuate more than ± 0.02 K.

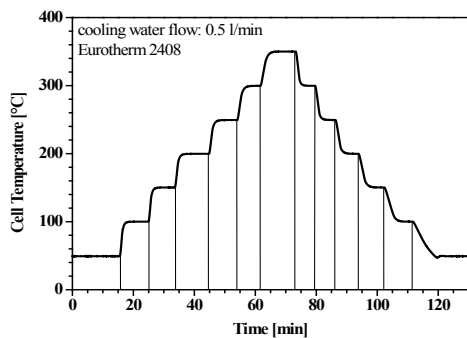
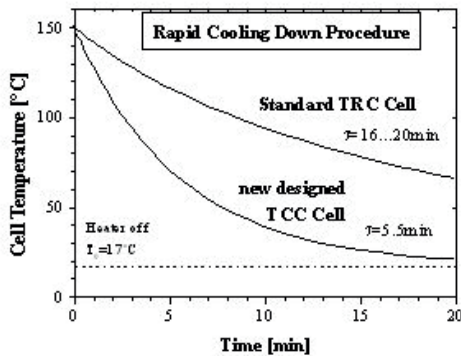

The cooling rate of conventional effusion cells with Thermal Radiation Cooling (TRC) increases with cell temperature according to the Stefan-Boltzmann-Law while the cooling rate of a TCC cell increases linearly with temperature.

Despite its larger thermal mass the cooling rate of the TCC cell is much higher at low temperatures and reaches 10°C/min even at 70°C cell temperature.

TCC cell and TRC cell during cooling down procedure are compared in the first diagram on the left. It shows the resulting temperature decrease of both cells starting at the same cell temperature of 150°C. The TCC cell cools down four times faster.

The short heating up and cooling down times of the OME are shown in the second figure. It is remarkable that no temperature overshoot is found in the heating up steps.

Its excellent low temperature properties make the OME cell ideally suited for evaporation of temperature sensitive materials like organics or polymers. Rapid heating up and cooling down rates avoid waste of expensive materials during non-operation times.

Technical Data

Mounting flange	DN40CF (O.D. 2.75") or larger
Dimensions in vacuum	L=220-400 mm
Heating system	encapsulated Ta-wire heater with patented TCC technique
Thermocouple	NiCr/NiAl (type K)
Bakeout temperature	max. 250°C
Operating temperature / stability	15°C ¹⁾ - 300°C ²⁾ ; < ±0.02K
Cooling	integrated water-cooled heat sink; min. water flow >0.5 l/min
Crucibles	2-35 cm ³ ; quartz (Q); other materials and sizes on request
Options	integrated rotary shutter (S); tight sealing shutter (TS)

1) lowest operation temperature depends on cooling media temperature
2) 350°C possible for short term operation

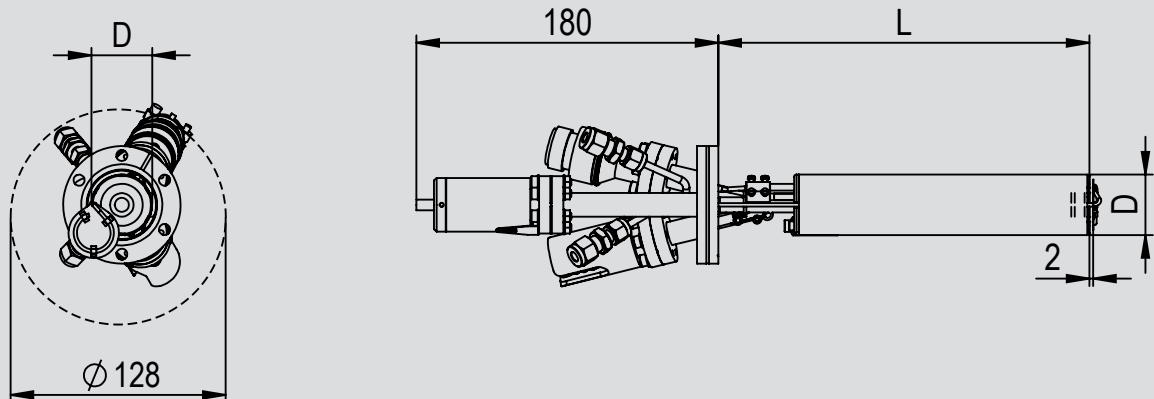

Schematic drawing of the Organic Material Effusion Cell OME (Drawing shows OME 40-2-25-S with integrated shutter)